

## Charged Capacitor Protection Circuit for the QuadTech Digibridges

All Digibridges are protected from damage from charged capacitors. However, no matter how much internal protection is provided, there will always be some combination of voltage and energy that can damage the front end of a Digibridge (or any bridge for that matter). Protection can be improved by adding components in the test connections. Although these components should be selected so that they will not affect measurement accuracy, typically this is not a problem.

A suggested external circuit is shown in Figure 1. Here, all diodes are small power rectifiers capable of carrying several amperes peak current but having reasonable capacitance at low signal levels (less than 100pF). Suggested values for the resistors in ohms are:  $R3 \ \& \ R2 > E/5$  and  $R1 \ \& \ R4 > E/20$ , where  $E$  is the possible peak voltage in volts. Being very conservative, the power rating of the resistors should be  $E^2/R$ . This may result in very large power ratings that may not be practical. Wire wound resistors usually can tolerate a large short overload and for them a rating to the possible peak energy in joules  $CV^2/2$  will usually be sufficient.

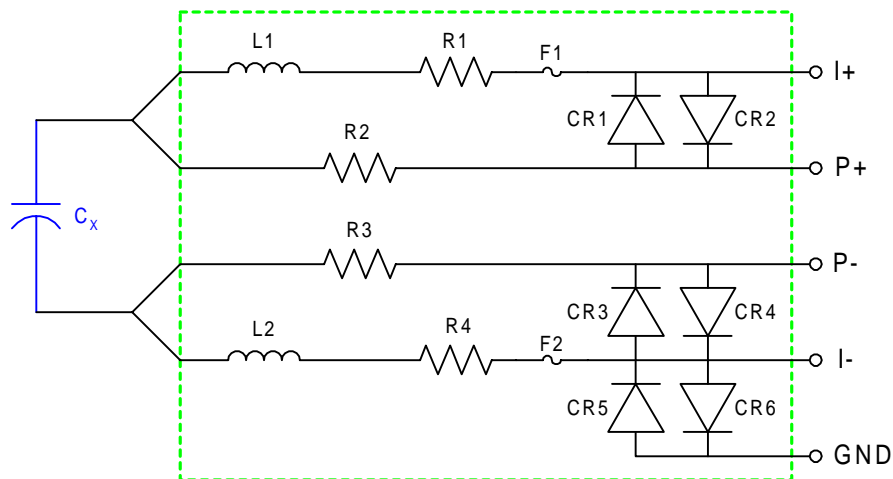

**Figure 1: Digibridge Protection Circuit**

### Suggested Values of Components

Resistor:	R1, R4	10Ω wire wound 2W
Resistor:	R2, R3	200Ω wire wound 2W
Inductor:	L1, L2	470uH 190mA
Diode:	CR1 to CR6	IN4005 rectifier
Fuse:	F1, F2	200mA fast blow

## Trouble Shooting the Component Values

These added components can cause errors under certain conditions and may have to be modified in value. The values given are conservative so they may be somewhat reduced. The rectifiers, CR5 and CR6 put stray capacitance to ground which can cause an error when making low capacitance measurements at higher frequencies. If this is the case, these rectifiers should be omitted from the circuit and the resistor R4 should be increased in value by a factor of four.

The resistor R1 reduces the drive signal but if much larger than the source resistance of  $25\Omega$ , it will result in noisy measurements. Resistors R2 and R3 generally can be of the suggested values, but they could cause D or Q errors at high frequencies. Resistor R4 reduces the current just as R1 does and it also introduces a common-mode voltage on the Ex measurement. It is preferable to keep  $R4 < 1/CCx$ . If adding R4 causes an appreciable error for low frequency measurements, it is suggested that Schottky power rectifiers be used for CR5 and CR6 and R4 be reduced in value. The rectifier should be able to tolerate a peak current of  $E/R$ . Adding a small inductor and fuses may also provide added protection.

Note that the circuit has been tested under a variety of conditions. All values given are conservative and will provide substantially improved protection, but we cannot guarantee that this protection will be good enough in all cases. In any event, both for safety of the operator and protection of the Digibridge, capacitors should always be discharged after a high voltage test.



Figure 2: 1689 and 1693 Digibridges

For complete product specifications on the 1600 Digibridge Line or any of QuadTech's products, visit us at <http://www.quadtech.com/products>. Do you have an application specific testing need? Call us at 1-800-253-1230 or email your questions to [info@quadtech.com](mailto:info@quadtech.com)

The information presented here is subject to change and is intended for general information only

©QuadTech, Incorporated

Telephone: 1- 800-253-1230, Website: <http://www.quadtech.com>

Printed in U.S.A.

P/N 035043

February 2002